

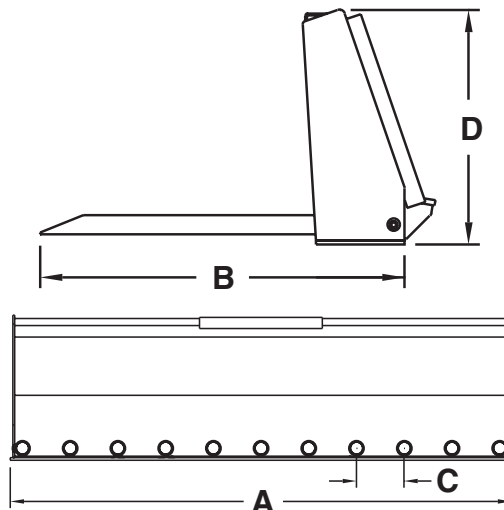

Utility Fork

MODEL	MV48	MV54	MV60	MV66	MV72	MV78
A) Overall Bucket Width	49.0 in.	55.0 in.	61.25 in.	67.25 in.	73.25 in.	79.25 in.
B) Depth of Bucket	33.0 in.	33.0 in.	33.0 in.	33.0 in.	33.0 in.	33.0 in.
Number of Teeth	7	8	9	10	11	12
C) Tooth Spacing (on center)	7.63 in.	7.38 in.	7.18 in.	7.06 in.	6.94 in.	6.81 in.
D) Height of Bucket	21.5 in.	21.5 in.	21.5 in.	21.5 in.	21.5 in.	21.5 in.
Approximate Weight	340 lb.	380 lb.	585 lb.	615 lb.	655 lb.	695 lb.
Bucket Teeth (1045 round)	1.5 in. Diameter		1.75 in. Diameter			
End Plates	1/4 in. Plate					
Wrapper	1/4 in. Plate – Reinforced					



Utility Fork with Grapple

MODEL	MGV160	MGV166	MGV172	MGV178
A) Overall Grapple Width	56.88 in.	56.88 in.	56.88 in.	56.88 in.
B) Height with Grapple Closed	27.63 in.	27.63 in.	27.63 in.	27.63 in.
C) Grapple Opening	38.0 in.	38.0 in.	38.0 in.	38.0 in.
Approx. Weight (Bucket & Grapple)	875 lb.	905 lb.	950 lb.	990 lb.
End Plates	3/8 in. High Tensile Plate			
Grapple Forks	1/2 in. High Tensile Plate			
Grapple Pins	1.25 in. Diameter 1045 Round			
Cylinder Specifications				
Bore	2.0 in.	2.0 in.	2.0 in.	2.0 in.
Stroke	8.38 in.	8.38 in.	8.38 in.	8.38 in.
Rod Diameter	1.25 in.	1.25 in.	1.25 in.	1.25 in.
Cylinder Pin Diameter	1.25 in.	1.25 in.	1.25 in.	1.25 in.

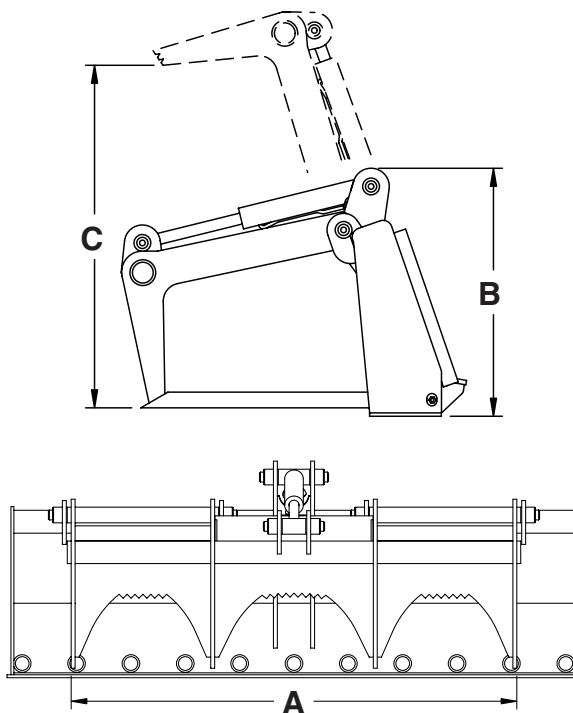

*Includes Hoses From Grapple To Skid Loader.
Couplers Available Upon Request.*

DISTRIBUTED BY:

[Innovative Loader Accessories](http://www.innovative-loader-accessories.com)
 1-888-339-7799

Specifications and designs are subject to change without notice.

Virnig Manufacturing, Inc
 800-648-2408
www.virnigmfg.com